

Intelligent Massage Chair

MD903

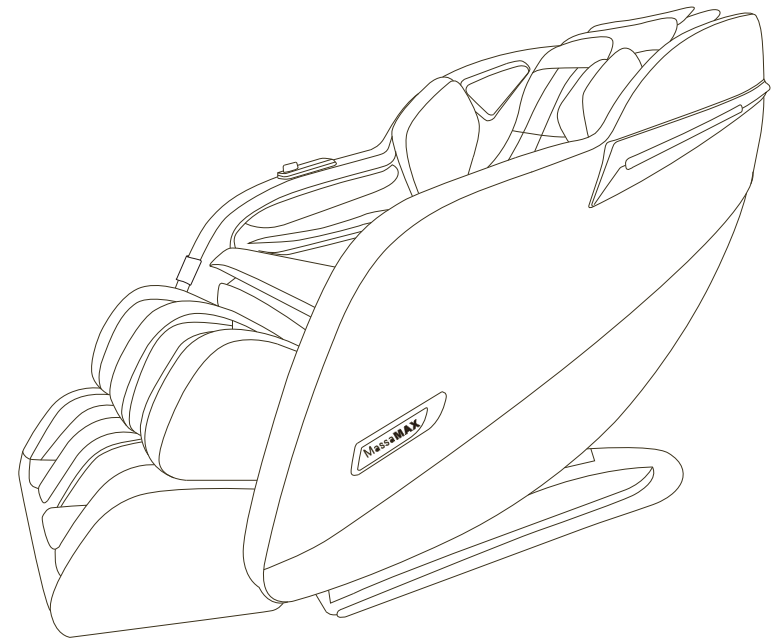







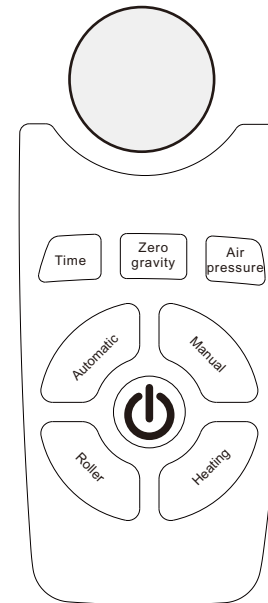

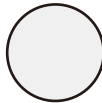
User Manual

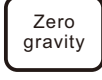
Contents

1. Safety Precautions	1-4
2. Product component name	5-6
A. Product appearance	5
B. Hand controller display	6
C. Installing the hand controller	6
3. Product operation instruction	7-10
5. Installation	11-12
6. Care and maintenance	13-14
7. Self inspection	15
8. Reference parameters	16
9. Shortcuts	17

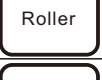

Button name	Function description
	Keep rotating this key to adjust the angle of the backrest up and down. Turn clockwise to lower the backrest. Turn counterclockwise to raise the backrest.
	Press this key to adjust the timing of the massage.
	Press the key to adjust the massage chair to the angle of zero gravity.
	Press the key to turn on / off the Air pressure function.

Button name	Function description
	After the power supply is connected, press the key to turn on the chair, and start Relax massage automatically for 15 min by default. Press it again to stop the massage, and the chair will go back to the upright position.
	Press the key to switch the automatic programs.
	Press this key to switch the manual program.
	Press this key to turn on / off the roller function.
	Press this key to turn on / off the heat function.





Reference parameters



Pecifications	
Operating Voltage	AC120V/60Hz
Power	140W
Working time	The default 15minutes/time,adjustable choose the 5/10/15/20/25 to 30min
Auto mode	12 Modes
Chair Size(Upright)	58 "L×29. 92"W×44"H
Chair Size(Reclined)	69"L×29. 92"W×34"H
Required Recline Clearance	9"
Specifications are subject to change without prior notice.	



- Please read this [Safety Precautions] carefully before use, and use this product correctly.
- The precautions in this section indicate the safe and correct use of the product to prevent possible harm or damage to the product, the user and others.
- This precaution is distinguished by [Warning] and [Caution] according to the severity of the hazard or damage that may be caused by improper operation. It is vital and must follow.

	Warning	Improper operation may cause serious injury to the user.
	Caution	Improper operation may cause injury to the user and damage to the property. Property damage refers to related damage to houses, property, livestock, pets, etc.

【Conventional signs】

	This symbol indicates warning or attention. (The picture on the left is generally used after warning or caution)
	This symbol indicates prohibited content. (The picture on the left is forbidden to disassemble)
	This symbol indicates mandatory or necessary content.

- After reading, save the manual where the user can see it at any time.

 **Warning**

- If there is smoke or abnormal sound (abnormal state), please disconnect the power immediately. After confirming the safety, please contact the dealer for repair. It is strictly forbidden to repair by yourself to avoid danger.



- Water in the host
- Sundries fall into the host
- Heavy falls or shell damage



Warning

 Prohibit	The following people are not allowed to use the massage chair. Thrombosis (blood disease, toxic aneurysm, acute vein tumor), various skin diseases or skin infections (including inflammation of subcutaneous tissue), etc.
 Comply with	<p>Please consult your doctor before using the massage chair:</p> <ul style="list-style-type: none"> · Patients with implantable medical devices in their bodies who are easily injured by electromagnetic influences. · Patients with malignant tumors · Patients with heart disease · Women in pregnancy or menstrual cycle · Patients with diabetes and peripheral circulatory disorders. · Perceptually impaired. · Persons with trauma in the massage site. · Those with a fever over 38°C, such as acute inflammation (typhoid fever, high blood pressure). · Those who are severely ill and physically weak. · Patients with fractures and acute bone pain · Patients with muscle sprains and muscle inflammation. <p>· In addition, if you feel unwell or need to be quiet, please use it with caution.</p> <p>The massage procedure of this product will cycle for 15 minutes. Please avoid continuous massage on the same part. If you need to continue to use it, please wait for more than 30 minutes to avoid excessive stimulation of the muscles or nervous system.</p>

Warning

 No wet hands	Never use it when your body is wet to avoid electric shock or machine failure.
 No humidity	This product can not be immersed in water or other liquids, and can not be used and stored in a humid environment such as a bathroom to avoid electric shock or mechanical failure.
 Must follow	Operate when confirming that there are no people or pets around.



If your chair has no power:

1. Check the power cord - Make sure the power cord connection to the chair is secure and that the power cord is not damaged.
2. Check the wall outlet - Plug a known working device into the outlet to ensure the outlet is working.
3. Replace the fuse - Use a flat-head screwdriver to turn the fuse holder (located next to the power switch) counter-clockwise until it pops out. Replace the fuse with one of the spare fuses that came with your chair, or any 250V, 3.15A fuse.

Just like with any other electronics, this simple reset sequence will resolve many issues. If, however, your issue remains, Please contact us.





Care and maintenance

3. To prevent damage to the upholstery, please ensure that there are no sharp objects in your pockets before sitting on the chair. No metal buttons and zippers can reach the chair.
4. Do not place the chair where there is too much dust and pet hair; they will migrate into the electrical and mechanical parts of the chair, which may cause malfunction.
5. When not used for a long time, please recommend wrapping the power cord, covering the chair, and placing the product in a dust-free and moisture-free environment.
6. Storage room temperature: -5°C to 35°C. Relative humidity (RH) between 20% and 80%; free of corrosive gases, and a well-ventilated room.
7. Do not store in or near an open flame.



Safety Precautions

 Disassembly prohibited	<p>It is forbidden to disassemble or repair this product, power cord, hand controller and other components by yourself to avoid electric shock, fire accident or machine failure. When the power cord is damaged, it is prohibited to disassemble and replace it privately. It must be repaired or replaced by the manufacturer or qualified professionals.</p>
 Prohibit	<p>Do not use damaged power cords. Do not forcibly bend, pull, twist, or damage the power cord, and do not hang heavy objects on the power cord. A damaged power cord may cause electric shock, short circuit or fire accidents.</p>



Warning

 Prohibit	<p>The massage chair will automatically change its angle during the automatic program. It is forbidden to come close to cracks and gaps to avoid injury.</p>
	<p>Do not use power sources other than AC 120V. The power cord cannot be wrapped around the product to avoid electric shock, short circuit or fire accidents.</p>
	<p>Do not allow children to ride or play on this product to avoid injury or cause malfunction of the machine.</p>
	<p>When adjusting the chair back and seat and adjusting the leg lift, make sure that there are no other persons, pets or objects behind the back and under the leg. During the adjustment process, do not place any part of the body, including hands and feet, in the gap between the backrest and seat, backrest and armrest, armrest and shoulder, seat and armrest cover to prevent injury.</p>
	<p>Do not use this product naked to avoid skin damage.</p>
	<p>Please be sure to use this product according to the instruction described in this manual, and do not sit directly on the legs or armrest parts to avoid injury or accidents.</p>
<p>The chair cannot be used to avoid injury or accidents when the body cover is disassembled or damaged.</p>	



 Comply with	Please turn off the power switch and unplug the power plug immediately when not in use or when the power is cut off to avoid electric leakage, electric shock or fire accidents when the power is turned on again. Please turn off the main power switch if not used for a long time
 No wet hands	Do not touch the power socket, plug or power cord with wet hands to avoid electric shock.
 	When cleaning and tidying up, turn off the power switch and unplug the power plug from the power socket to avoid fire or electric shock. When opening the power plug, do not pull the power cord forcibly, but hold the plug to avoid accidents.
 Prohibit	Do not use this product immediately after eating or drinking to avoid physical discomfort. Do not hang heavy objects on the power cord or control cord, The manual controller cannot be impacted or dropped by external force to avoid unintended operation, malfunction, electric shock or fire accidents. Please do not use this product near fire sources or heaters, and do not use it on floor heating or other heated floors. Do not smoke during use to avoid fire.

Warning

 Prohibit	This product can only be used in general household places, please do not use it in other places. Please do not use this product when it is covered by blanket or others to prevent the machine's internal temperature from becoming too high and causing a fire accident. Please ensure that the power plug and the power socket match well. Do not use wiring board to avoid electric shock, short circuit or fire accidents. Do not stand, step on or stack heavy objects on the body or legs of the machine to prevent personal injury or machine failure. Do not use this product near fire sources or flammable materials to avoid product deformation, machine failure or fire accidents. Do not use this product in an environment with a high concentration of floating chemicals such as oil and gas to avoid product deformation, machine failure or fire accidents. Do not spray this product with organic solvents, alcohol or pesticides to avoid cracks in the machine, electric shocks, or fire accidents. During use, do not let children or mentally handicapped approach the machine to avoid injury accidents. Paralyzed people cannot use this product to avoid physical discomfort or injury.
--------------	---



To keep your product working and looking its best, please follow these simple care guidelines.



WARNING:

1. Remind the power cord from the electrical outlet before cleaning.
2. When cleaning the remote control or power switch, use a dry cloth only. Never use a damp cloth to clean any electrical component.



CAUTION:

1. Be sure to test any cleaning solution on a small, inconspicuous part of the product to ensure that the color does not fade before using the solution on the entire product surface.
2. Do not use benzene, thinner or any other solvents on your product.
3. Cleaning Code Standard for SofHyde or Cloth: W
4. To maintain your product in optimum condition, dust it frequently and/or vacuum it with a soft brush vacuum extension. If your product becomes dirty, use a water-based upholstery cleaner only. To treat stains, spot clean with an upholstery shampoo or a mild detergent foam.

Maintenance and Repair:

1. The mechanics of this product are specially designed and constructed to be maintenance free. No periodic lubrication or servicing is required.
2. A service representative should only service your chair.

Use and Storage Environment:

1. Do not place the chair in direct or reflected sunlight, as ultraviolet rays will quickly fade the upholstery color and cause SofHyde upholstery to rapidly deteriorate rapidly.
2. Operate your chair in a room temperature between 5 to 35 degrees Celsius with humidity levels of 20% to 80%; free of corrosive gases, and a well-ventilated room.



- *If the aisle width is less than 90cm, the massage chair cannot be moved normally.
- *If the massage chair cannot be moved normally, please contact the dealer who sold it.
- *Please do not drop the massage chair when moving in and out due to the heavy height of the massage chair,
- *Please do not move the massage chair when man is on that.
- *Please unplug the power plug from the socket before moving the massage chair.
(The power plug may be damaged, cause fire or electric shock.)

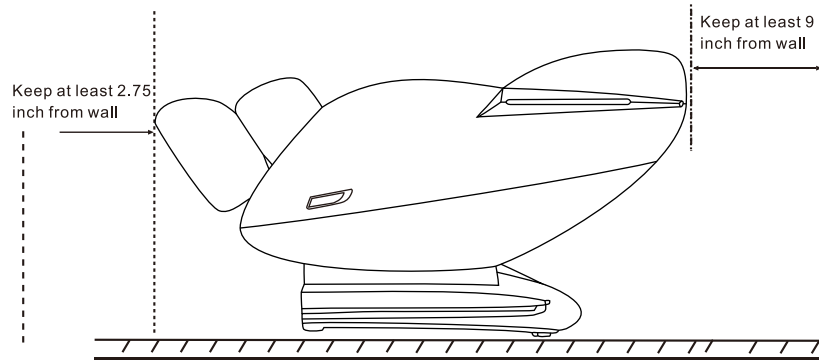

- A. When deciding where to place your chair, consider the following:
1. Place the unit on a flat surface, away from direct sunlight or any other direct heat source (to avoid fading).
 2. If you wish to place the unit on a hard surface, it is recommended that you place a piece of carpet or a soft mat underneath it to avoid damaging the floor .
 3. To accommodate the footrest when deployed, make sure the area at back of the chair is clear for at least 9 inches.
 4. Do not to use it in the places with heavy humidity such as bathrooms or saunas .



Product appearance

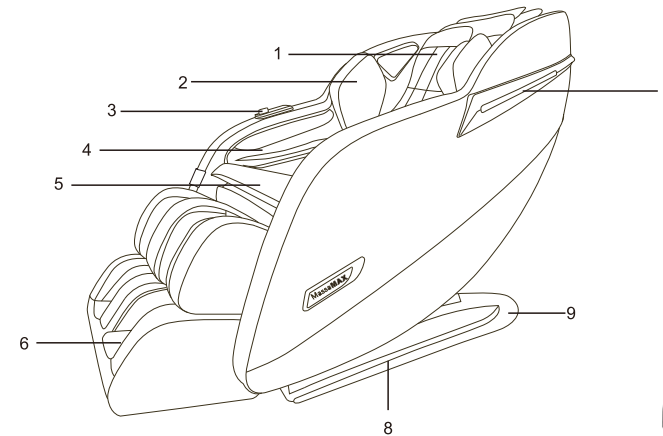

- 1、Pillow
- 2、Shoulder airbag
- 3、Shortcut keys
- 4、Arm airbag
- 5、Seat cushion
- 6、Legrest
- 7、Atmosphere lights
- 8、Side plate
- 9、Chair base

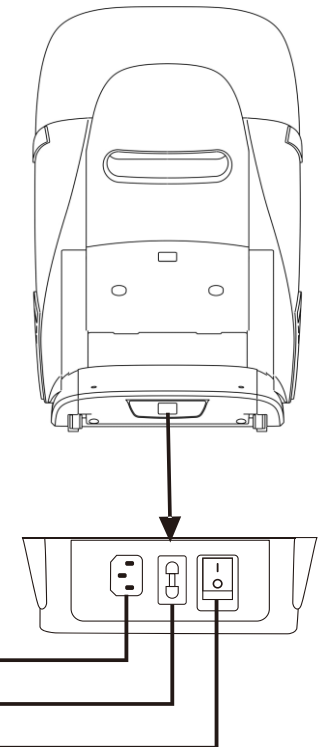

Plug outlet
Fuse 3.15A
Power switch



Hand controller display

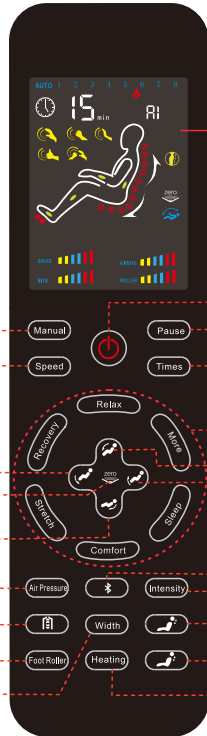

LCD

Massage Technique

Speed+/-

Legrest Down
Zero Gravity

Backrest Down

Airbag Auto ON/OFF

Section

Foot Roller ON/OFF

Width

Power
Pause

Time+/-

Auto mode

Backrest Up
Legrest Up

Blue tooth ON/OFF
Airbag Intensity +/-

Shoulder position UP

Shoulder position Down
Heating

- Before use, you need to connect the hand controller and make sure the power supply is OFF.
- *Do not spill water or other liquids on massage chairs or the hand controller.
 - *Do not install it with wet hands.
 - *Do not sit on the hand controller, or fall off or trample it, and do not forcibly pull the wires.
 - *Do not press the LCD screen with sharp or hard objects. (Or it may cause damage)



Installation

The Legrest Installation

Step 1

- Connect the wires and the air hose between chair seat and the leg rest, confirm whether the docking is in place.
- Unfasten the black pipe belt and insert the connecting part into the seat frame. P.S Avoid tracheal dying when entering.

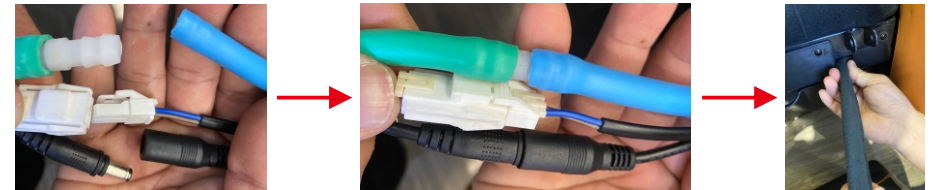

Step 2

- Fetch the parts (A/B/C) from bag .
- Place part A insert legrest left and right sides.
- Place part B insert the hole, from inside to outside.
- Insert part C into the hole of part B. P.S Hide the parts after install the legrest .

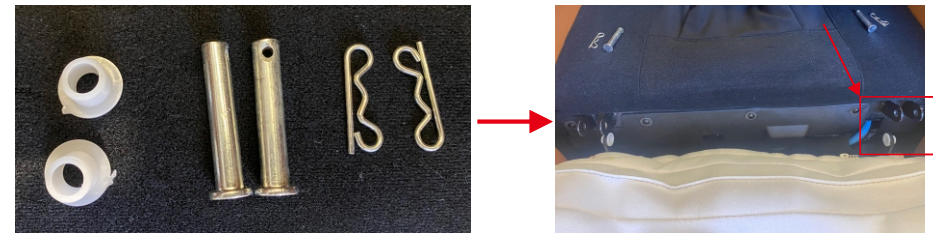

A B C

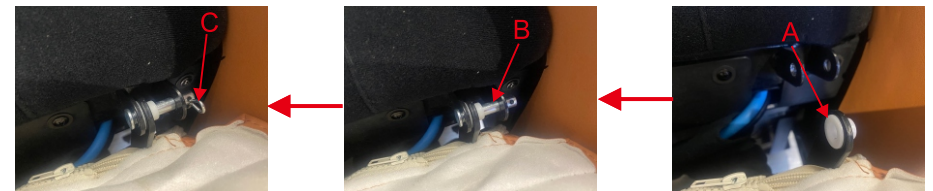



Manual Procedure

Press the manual mode button and enter the manual massage mode.

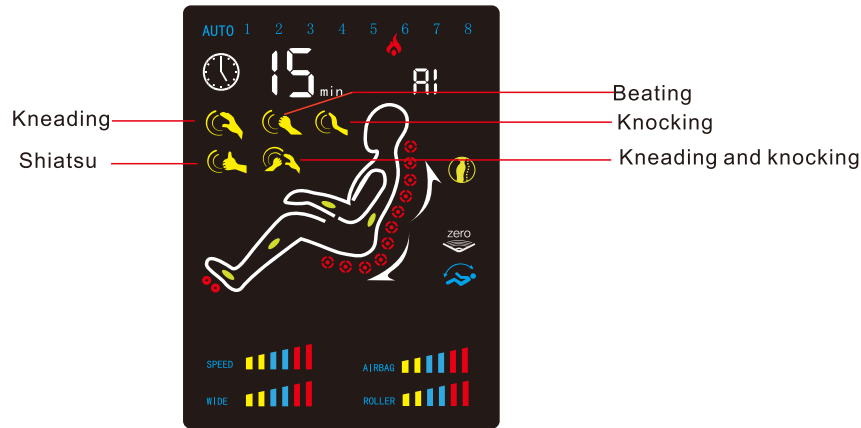

Press the "Manual " button to switch massage techniques. The upper left corner of the screen shows the current massage technique.

Entering manual mode, all functions can be adjusted and operated following by the button functions of hand controller.

Bluetooth connection instructions

Turn on the Bluetooth on the mobile phone to search for Bluetooth, find the local Bluetooth (Massage), match successfully, turn on the Mobile Music and play music.



Button name	Function description
	When the power supply is connected ,press it firstly to turn on the chair,and it works immediately for the default automatic mode "Relax massage" mode, and the default working time is 15min .Press it again to stop the massage,and the chair will be back to the upright position.
	Press this key to switch the manual programs. Accord , tapping, condition and massage time, you can switch kneading horization, knocking, finger pressing, kneading and tapping sync - kneading and tapping synchronization, squeezing, etc
	The button stops all massage function temporarily, Press the button to stop function temporarily; Press again to resume
	Press it to adjust the massage speed. There are three levels for adjustment.
	Press it to adjust the massage time. The adjustable time is 10 / 20 / 30 minutes.
	(LCD Display: A1),Deep-tissue massage throughout key acupressure points to relax the sore area.
	(LCD Display: A2),Restore the full body from fatigue and pain
	(LCD Display: A3),Move your body parts up and down through the leg rest and the backrest with airbags and rollers massage.
	(LCD Display: A4),Help loosen the muscles and comfort.
	(LCD Display: A5),It helps the body to adjust the balance, hoping quickly improve your sleep and sleep quality.
	Press it to switch more auto massage mode(A6-b6), see Page 09 for more details
	Press and keep holding the button to raise the backrest
	Press and keep holding the button to lower the legrest
	Press and keep holding the button to lower the backrest



Button name	Function description
	Press and keep holding the button to lower the legrest
	Press it to turn on/off the zero-gravity massage
	Airbag auto ON/OFF Button
	Bluetooth Button On/Off
	Air intensity adjust Button
	This button allows you to limit the massage to a particular body zone Press once to fix the currently position of massage mode, Press it second time to keep the massage mode moving on a range of 10cm Press it third to resume the full back massage
	In manual mode ,press it to adjust the width of the massage head, which can be selected as wide,medium and narrow
	Long press it to move up the massage part of the manipulator. Release it in the manual mode to make the mechanism stay at the current position.
	Foot Roller ON/OFF Button
	Press this key to turn on/off the heating function
	Long press to move down the massage part of the manipulator. Release it in the manual mode to make the mechanism stay at the current position.

PS: The chair will not reset by default after the "Auto Mode" finished
press the " " button can the chair be reset and turned off.



Function description

12 Automatic Modes:

Mode Name	Program features	LCD display
Relax	Deep-tissue massage throughout key acupressure points to relax the sore area.	A1
Recovery	Restore the full body from fatigue and pain	A2
Stretch	Move your body parts up and down through the leg rest and the backrest with airbags and rollers massage.	A3
Comfort	Help loosen the muscles and comfort	A4
Sleep	It helps the body to adjust the balance, hoping quickly improve your sleep and sleep quality.	A5
More	Relief:Quickly relieve fatigue in the back and limbs	A6
	Shoulder & Neck:Focus on the shoulder and neck massage.	b1
	Back & Waist:Focus on the back and waist massage.	b2
	Waist & Hips:Focus on the waist and hips massage	b3
	Office regimen:Powerful massage for sore areas common to office workers.	b4
	Lady:Effective massage on fatty areas, supplemented by full body relaxation to help shape your body.	b5
	Older:Gently massage the entire body to help relax the mind and body	b6

PS: After turning on the massage chair, there will be three "Di-Di-Di"prompt tones, which means the chair will enter the shoulder detection. At this time, you can long press the "" or "" button to adjust the shoulder position of the machine. After releasing, the chair will be on the first automatic program "relax"mode after another three "Di-Di-Di"prompt tones.

Functions that can still be used in automatic mode:

Foot roller button, Zero button,Heating button, Backrest up button,
Backrest down button, Time button, Airbag strength button,
Intensity air pressure button.